

Rototech



'Ex d' Explosion Proof Motor
Installation & Maintenance
Manual
YB2-250-280



Phone 1300 553 552 (24Hours) www.rototech.com.au

ROTOTECH

INDEX

1. INTRODUCTION.....	2
2. INSTALLATION OF THE EXPLOSION PROOF MOTORS.....	6
2.1 SUITABILITY OF THE MOTOR TO THE OPERATION LOCATION.....	6
2.2 NAMEPLATE DATA CONCERNING SAFETY ASPECTS.....	7
2.3 POWER SUPPLY, AUXILIARY AND GROUND CONNECTIONS.....	7
2.3.1 AUXILIARY CONNECTIONS.....	9
2.4 CABLE ENTRANCES.....	9
2.5 THERMAL PROTECTION DEVICES.....	11
3. CHECKING, REPAIRS & MAINTENANCE OF THE EXPLOSION PROOF MOTORS.....	12
4. FLAME PATH DIMENSIONS.....	14



1. INTRODUCTION

1.1 These instructions concern installation, use and maintenance of the motors operating in hazardous areas and in the presence of potential explosive atmospheres. The motors subject to these instructions are designed with the following types of explosion proof protection:

Ex d I/II B T4/T5: Equipment protection by flameproof enclosure “d”

Rating:

Motor Frame: YB2-250-280

Rated voltage: 380V-1140V

Frequency: 50Hz, 60Hz

Pole: 2P, 4P, 6P, 8P

Rated power: 22-110kW

IP55, IP56 or IP66

Insulation class: F or H

Duty: S1

Cooling: IC411

Motors are adopted horizontal mounting and vertical mounting (foot mount and/or flange mount). Motor is composed of main body/main terminal box and two auxiliary terminal boxes (one is heater junction box, the other one is stator temperature sensor terminal box), two bearing RTDs' terminal box as an option. There are terminal bushings between main body and terminal box. The material of bushing is 4220 DMC. The material of inner bearing



cover and auxiliary terminal box are gray cast iron HT250, the enclosure of main body, endshield and terminal box are made from Q235-A steel. The motor adopted the self-driven external cooling fan; the material of the fan is Q235-A steel. There is a cable entry with rubber sealing ring in the terminal box.

1.2 Motor type explanation:

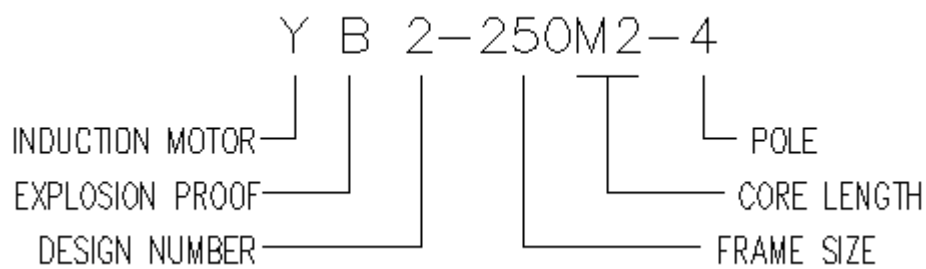

1.3 Motor rating list

RATING TYPE	POWER(kw)		POLE	FREQUENCY	VOLTAGE	IP CLASS	COOLING	DUTY	Ins.CL.
	T4	T5							
YB2-250M-2	55	41	2	50/60HZ	380-1140V	IP55 IP56 or IP66	IC411	S1	F or H
YB2-250M-4	55	41	4						
YB2-250M-6	37	27	6						
YB2-250M-8	30	22	8						
YB2-250M2-2	75	56	2						
YB2-250M2-4	75	56	4						
YB2-280S-2	75	56	2						
YB2-280S-4	75	56	4						
YB2-280S-6	45	33	6						
YB2-280S-8	37	27	8						
YB2-280M-2	90	90	2						
YB2-280M-4	90	90	4						
YB2-280M-6	55	55	6						
YB2-280M-8	45	45	8						
YB2-280M2-2	110	82	2						
YB2-280M2-4	110	82	4						
YB2-280M2-6	75	56	6						
YB2-280M2-8	55	41	8						

!! Motor for hazardous areas are specially designed to comply with official regulations concerning the risk of explosion. If improperly used, badly connected or modified, no matter how minor, their reliability could be in doubt.

Standards relating to the connection and use of electrical apparatus in hazardous areas must be taken into consideration.

Only trained personnel familiar with these standards should handle this type of apparatus.

2. INSTALLATION OF THE EXPLOSION PROOF MOTORS

2.1 SUITABILITY OF THE MOTOR TO THE OPERATING LOCATION

The suitability is related to the zone classification and to the characteristics of

the inflammable materials present in the installation area.

The essential “Ex safety” requirements for the classified hazardous areas comply with the IEC standards:

IEC 60079-0:2004 Electrical apparatus for explosive gas atmospheres-Part 0: General requirements

IEC 60079-1:2007-04 Explosive atmospheres-Part 1: Equipment protection by flameproof enclosure “d”.

The choice of the type of motor must take into account the following factors:

Type of unit: underground mines (group I), surface (group II).

Zone classification: 1, 2 (for which are suitable components of 1, 2, 3 category).

Characteristics of the inflammable materials present as a gas, vapour / gas.

Group of application: I, II A, II B.

Temperature classes: T1, T2, T3, T4, T5 (according to the highest admissible surface temperature of the machinery and according to the ignition temperature of the combustible materials).

2.2 NAME PLATE DATA CONCERNING SAFETY ASPECTS

Ex d	Explosion proof motors
I	Enclosure of the group I, used for underground mine
II B	Enclosure of the group II B, suitable for materials(gas) of the group II B
T4/T5	Class of temperature of the motor (maximum surface temperature), according to the equivalent class of temperature of the combustible material.
Ex	Mark of conformity to relative IEC standard and the respective technical regulations.
IEC Ex xxxxx xx.xxxx	Certificate number including the certificate issue body's name



Notes:

- The motors of the group II B are suitable for the group II A.
- The motors of a given class of temperature are suitable for combustible materials of a greater class of temperature (example, T5 motors are suitable for material of class T4, T3, T2, T1).
- The normal range of ambient temperature, for the Ex motors, is: -20°C / $+40^{\circ}\text{C}$ (if the motors are used on different ambient temperatures, this must be specified at the time of order and marked on the name plate).

2.3 POWER SUPPLY, AUXILIARY AND GROUND CONNECTIONS

The connections have to be made to the following diagrams below:

Connection ways:

- a) Main Terminal box sketch (including the connections of the winding cables to the bushing).



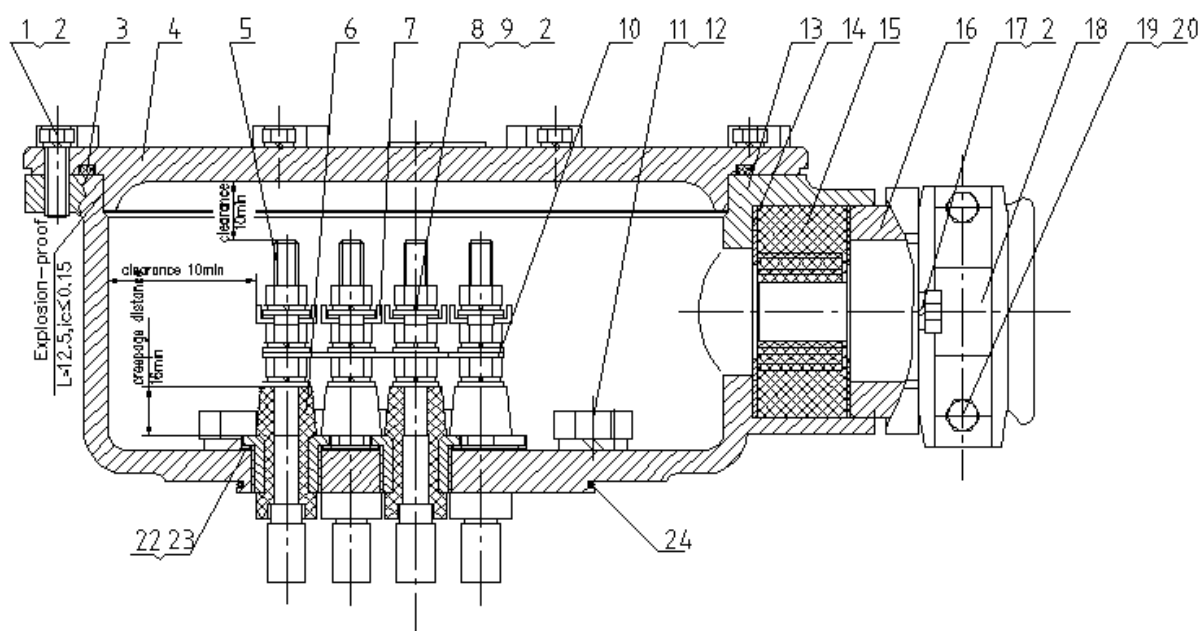

- | | | |
|------------------------|------------------------|------------------------|
| 1 Bolt M10X35 | 9 Plain washer 10 | 17 Bolt M10X40 |
| 2 Spring washer 10 | 10 Connecting sheet | 18 Platen |
| 3 Rubber seal 270X3.55 | 11 Bolt M16X55 | 19 Bolt M8X25 |
| 4 Terminal box lid | 12 Spring washer 16 | 20 Spring washer 8 |
| 5 Connection bolt | 13 Terminal box base | 21 earth screw M10X25 |
| 6 Terminal block | 14 Metal washer | 22 Stop gasket |
| 7 Bows gasket | 15 Ring | 23 Gasket |
| 8 Nut M10 | 16 Junction Box Bucket | 24 Rubber seal 160X1.8 |

Connection diagram Δ Conn.

Connection diagrams Y Conn.

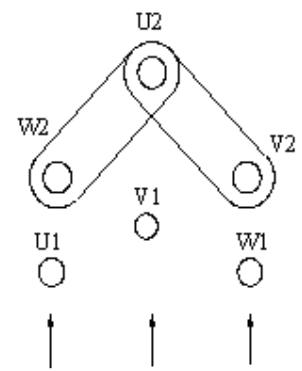
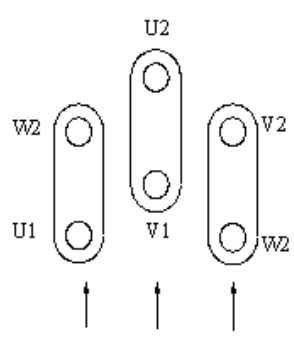

b) The Earth connection. There are Earth connections fitted to the Ex motors, inside the main & aux. terminal boxes, externally on the frame.

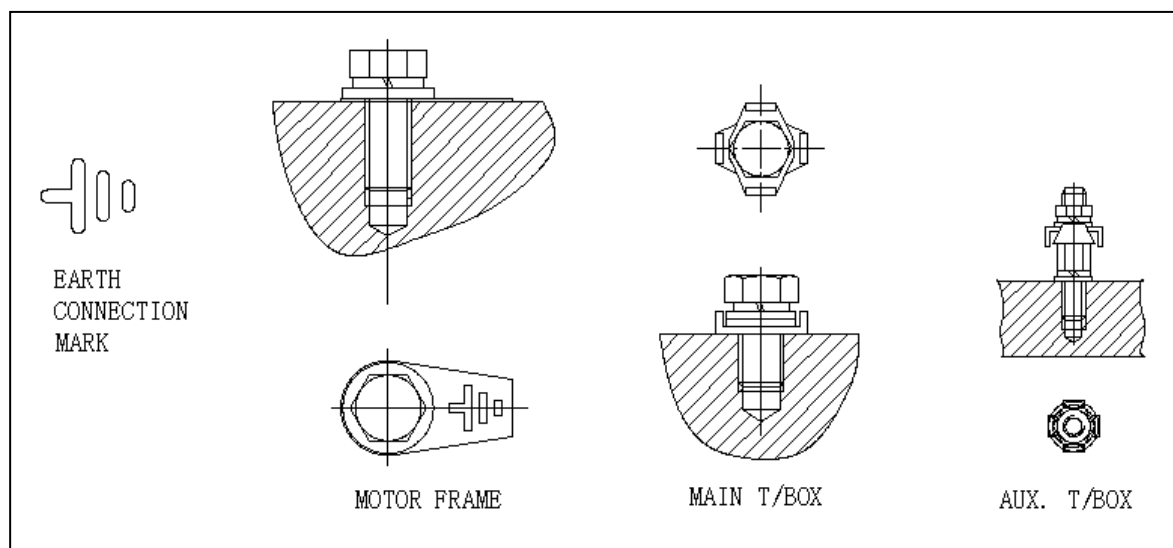

Winding RTD's T/Box (one set is connected, the other is spare)

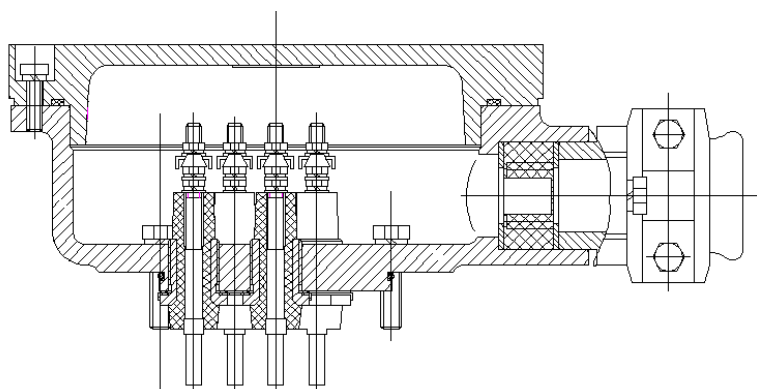

Connection diagram

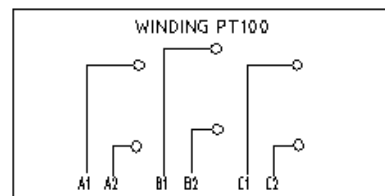

Heaters T/Box:

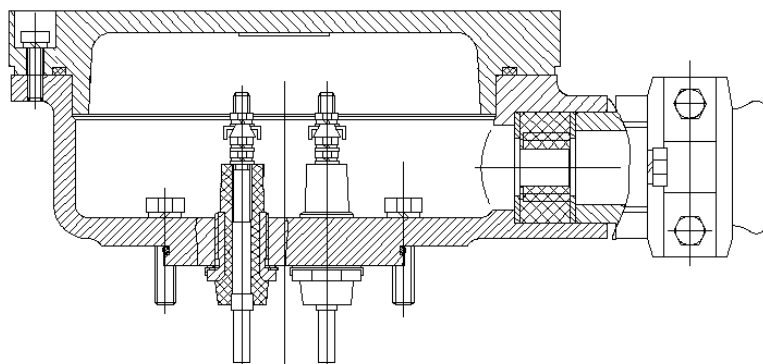

Connection diagram

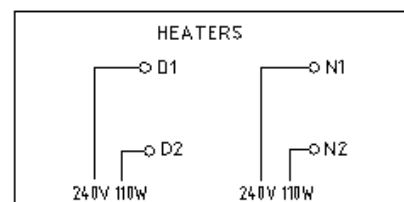

Connection torque list:

Screw size	M4	M5	M6	M8	M10	M12	M16
Torque(N.m)	1	2	4	10	15	20	40

2.4 CABLE ENTRIES

2.4.1 The main cable entrance can be adapted to the rubber sealing rings suitable for cable diameter $\Phi 25$, $\Phi 31$, $\Phi 36$, $\Phi 45$ and $\Phi 50$. When connected to the supply cable, it must be assembled & completely screwed in order to achieve the necessary pressure on the sealing rings, as:

- To avoid the transmission of mechanical vibrations to the motor terminals.
- To guarantee the mechanical protection “IP” of the terminal box.



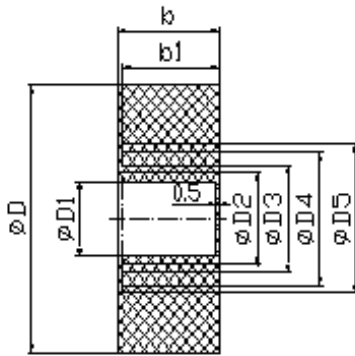

Select the correct diameter compression seal. Remove the smaller seals to match the larger cable size selected.

Ensure correct seal is selected to suit cable selected.

机座号 Frame No.	D1	D2	D3	D4	D5	D	b1	b
250 ~ 280	25	31	36	45	50	90 _{-0.87}	36	38

2.4.2 The cable entry can be of conduit thread construction by changing the T/Box gland as the follows, “M” dimension can be machined according to requirements to match the certified glands.

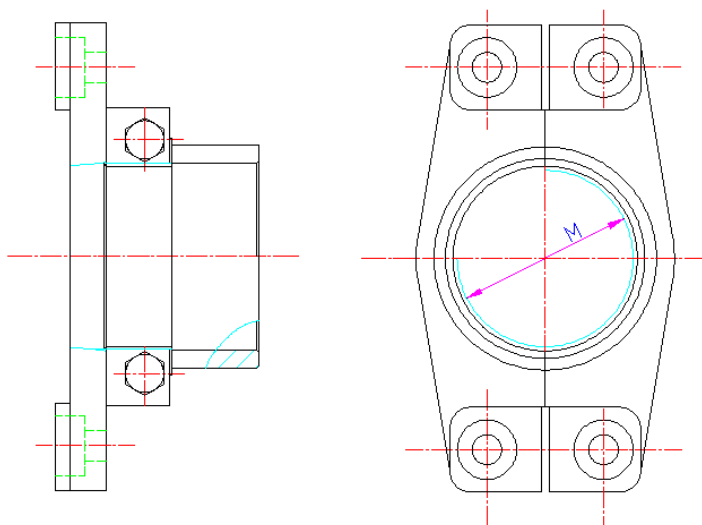

The cable entries for winding RTD and Heater are adopted similar constructions, the suitable cable diameter is: $\Phi 14$, $\Phi 20$ and $\Phi 26$.

Bearing RTD T/Box

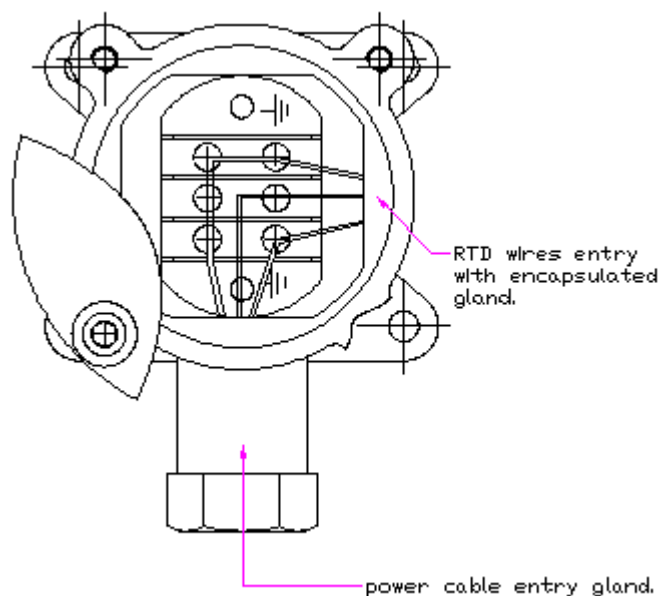

The suitable cable to bearing RTDs is: $\Phi 8$.

All the hard edge of cable entries are rounded according to standard requirements.

When seals require replacement, original seals supplied from the manufacturer must be used only.

When reassembling the cover to the terminal box, it is required to regrease the joint surfaces.

2.5 THERMAL PROTECTION DEVICES

2.5.1 Winding RTD's (Resistance Thermal Detectors) where fitted to the Stator Winding as Thermal Protection Devices. The Red's are embedded in the head windings, RTD leads are terminated in an auxiliary box.

The recommended temperature settings for safe operation of the motor are:

ALARM SETTING ***130 °C***

TRIP SETTING ***135 °C***

2.5.2 Bearing RTD's where fitted to the motor as bearing temperature monitoring devices. These RTD's are fitted to the outer bearing caps, the connection wires are protected with a stainless steel wire tube and terminated inside an auxiliary box. The recommended bearing temperature limit settings are:

<i>ALARM SETTING</i>	<i>80 °C</i>
<i>TRIP SETTING</i>	<i>85 °C</i>

Note: below label indicates the temp. range of RTD, not ambient temperature range of motor, temperature setting should be set as indicated above (winding and bearing RTDs).

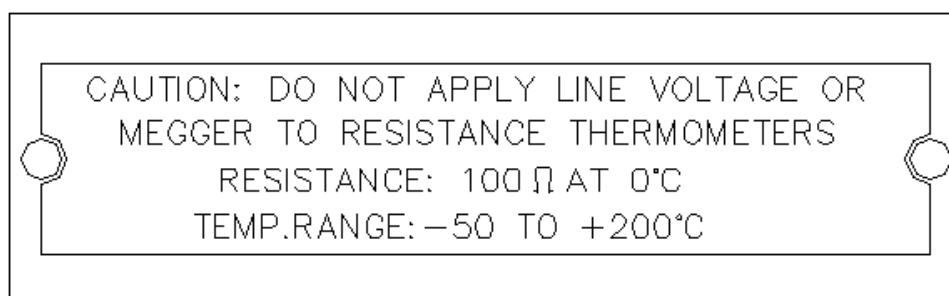

2.5.3 Anti-condensate Heaters are installed to prevent moisture condensation in the motor during periods the motor is not running. They are fitted directly to the winding coils and are terminated to an auxiliary terminal box. They require to be connected to the power when motor is not powered. Heaters are 230V, 99W.

2.5.4 Two sets of thermistors are fitted to winding and terminated to the main T/Box which has 2 cable entrances; the suitable cable diameter is $\Phi 14$, $\Phi 20$ and $\Phi 26$.

One set is for alarm: **130 °C**. One set is for trip: **150 °C**.

3. CHECKING REPAIRS & MAINTENANCE OF THE Ex MOTORS

Checking and the maintenance procedures of Ex motors is stated in IEC60079-17 standard.

Repair procedures of the Ex motors are stated in IEC 79-19 standard.

When it is not possible for repairs of Ex motors to be carried out at the manufacturer's plant, workshops assigned to this task must be accredited by the IEC Ex or Aus Ex certifying body.

Any repairs to any part of the Ex motor must be done without any modification to the original motor design.

The electric connections must be correctly torque to avoid resistance-increases with consequent contact overheating.

The insulation air-distance and the surface-distance between conductors required by the standards must be respected.

All the screws, used to assemble the parts of the motors and of the terminal box, must be completely screwed.

The replacement of seals and components for cable entrances must use spare parts supplied from the manufacturer in order to guarantee the original type of protection.

The Ex joint surfaces must not to be machined and any type of seal is not permitted on these joint surfaces. The joint surfaces must be clean & in order to avoid corrosion or water entrance, can be treated by means of a thin coat of silicon grease.



Post Repairs:

In the case of full conformity of the motor to the original standard and certificate, it is requested to fix on the motor frame (without removing the original one) an additional nameplate, with the following data:

- Mark **R**. (for Repair)
- Name or code of the “repair shop”.
- Number of the “repair operations”, performed by the repair shop.
- Repair date.

In case of non conformity of the motor occurs after the repair operations:

- The original nameplate must be removed; the motor will no longer be suitable for use in hazardous areas, with explosion risk.

4 FLAME PATH DIMENSIONS.

Gap (i)	1) The gap between frame and front endshield: $iC < 0.20$ 2) The gap between frame and rear endshield: $iC < 0.20$ 3) The gap between M10 terminal box base and box cover: $iC < 0.15$ 4) The gap between terminal bush and terminal bolt: $iC < 0.20$ 5) M5 terminal box. The gap between terminal box base and box cover: $iC < 0.20$ 6) Bearing temperature box. The gap between the box lid and box base: $iC < 0.15$
Spigot joints	1) Joint between frame and front endshield: $L > 27\text{mm}$ 2) Joint between frame and rear endshield: $L > 27\text{mm}$ 3) Joint between M10 terminal box base and terminal box cover: $L > 14.5\text{mm}$ 4) Joint between M10 terminal bush and terminal bolt: $L > 27\text{mm}$ 5) Joint between M5 terminal box seat and cover: $L > 14.5\text{mm}$ 6) Joint between bearing RTD temperature junction box seat and lid: $L > 15\text{mm}$.
Holes in joint surfaces	1) Joint between front endshield and inner bearing cover $L = 14.5\text{mm}, l = 15.0\text{mm}$ 2) Joint between rear endshield and inner bearing cover $L = 14.5\text{mm}, l = 15.0\text{mm}$ 3) Joint between frame and terminal box base: $L = 25.0\text{mm}, l = 17.0\text{mm}$ 4) Joint between frame and auxiliary terminal box base: $L = 18.0\text{mm}, l = 8.5\text{mm}$



Threaded joints	<p>1) Joint between M10 terminal box base and terminal bushing: cylindrical threaded joint (M30x2-6H/6g), minimum eight full threads engaged, thread pitch approximately 2.0mm, Minimum engagement length 17.0mm.</p> <p>2) Joint between M5 auxiliary terminal box base and thread bolt: cylindrical threaded joint (M20x2-6H/6g), minimum eight full threads engaged, thread pitch approximately 2.0mm, Minimum engagement length 17.0mm.</p> <p>4) Bearing temperature measuring box: Joint between terminal box base and connection bolt: cylindrical threaded joint(M12x1-6H/6g), 10 full threads engaged, engagement length 10mm.</p>
Cylindrical joints	<p>1) Joint between front inner bearing cover(front) and rotor: L=43.0mm, iC <0.40</p> <p>2) Joint between rear inner bearing cover and rotor: L=43.0mm iC<0.40.</p>
Rolling –element bearings	m≤0.267mm (the maximum gap permitted is 0.4mm).

