

# EUCR-2C Under Current Relay

Samwha

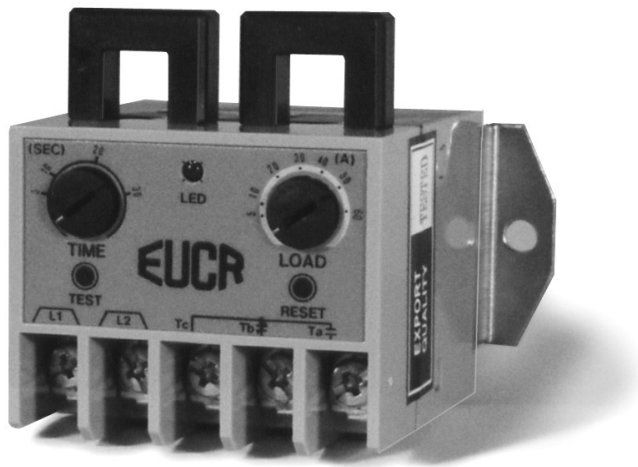

## Applications

- Pumping cavitation or loss of prime
- Detect malfunction of fans
- Broken belt or coupling failure
- Shut down motors when unloaded

## Features

- Adjustable underload protection
- Trip delay adjustment
- Wide current adjustment range
- Trip indication LED
- Remote electrical reset
- Low energy consumption/Compact design
- Operates in wide ambient temperature range

## Benefits

- Simple to commission
- Reduced spares inventory
- Assists in fault finding
- Safe remote reset
- Less cubical space required
- Consistent accuracy

The Samwha EUCR-2C under current relay has been designed to suit 3 phase motor and other under current applications. Current ranges from 0.5 amps to 60 amps are achieved by just three relays reducing the need for large numbers of spares. Two of the three motor or load cables are fed through the two integral current transformers mounted on the body of the relay. Circuits up to 600 amps capacity can be protected by using the EUCR-2C-05 model relay in conjunction with standard metering class current transformers (5 amp secondary). The secondary of the external current transformers feeds through the integral current transformers. For single phase applications, one external CT feeds through both integral current transformers. The relay can be reset either manually or electrically allowing remote reset as standard. It is simple to install being Din rail or surface mounting and offers very good value for money.

## Ordering Information

EUCR-2C - R -

- Control Voltage 24, 110, 220, 440
- Non Fail Safe
- Current range 05,30,60 or 100-600 amp with external current transformers

For further details please contact your Samwha distributor.

## Specifications

### TRIP TIMES

Under current Definite time 0.2-30 sec.

### CURRENT SETTING RANGE

05 Type 0.5 - 5 amps  
 30 Type 3.0 - 30 amps  
 60 Type 5.0 - 60 amps  
 100-600 Type With external current transformers

### CURRENT SENSING 2 CT

### CONTROL VOLTAGES

24 24V ac/dc  
 110 110 Vac  
 220 240 Vac  
 440 440 Vac  
 Other voltages available by request

### FREQUENCY 50/60 Hz

### OUTPUT RELAY

1- changeover contact  
 3A/250Vac resistive

### OPERATING CHARACTERISTIC

Definite time

### TRIP INDICATION Red LED

### TOLERANCE

Current +/- 10%  
 Time +/- 15%

### AMBIENT TEMPERATURE

Storage -30 - 80°C  
 Operation -25 - 70°C  
 Humidity 45 - 85%  
 without condensation

### INSULATION

Between casing and circuits  
 Over 10MΩ @ 500 Vdc

### DIELECTRIC STRENGTH

Casing & circuit 2kV  
 Between contacts 1kV  
 Between circuits 2kV

### POWER CONSUMPTION Less than 2 VA

### MOUNTING

35mm DIN rail/surface

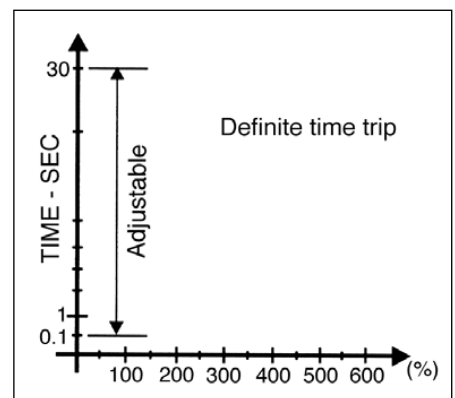

Time current characteristics

## Adjustments

The relay facia has two adjustments:

- 1) Trip time adjustment
- 2) Current adjustment

Each adjustment is calibrated so the relay can be accurately set with no control power applied.

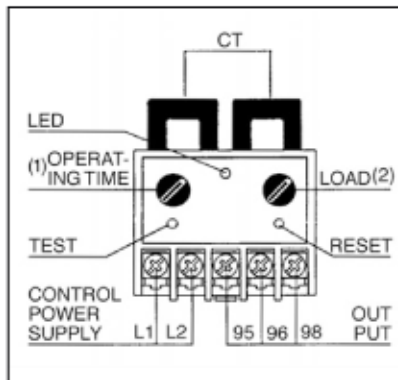

## Indication

The EUCR-2C provides undercurrent/trip indication via a red LED mounted on the front facia.

## Motor Underload Application

- Set the trip time adjustment (1) to the required trip time.
- Set the current adjustment (2) to the desired trip current.
- Once all the connections to the relay have been made in accordance with the typical wiring diagram control power can be applied when the motor is started (red LED off).
- Press and hold down test button (red LED on). The relay will trip after the trip time adjustment (1) has elapsed. The EUCR-2C can be reset manually via reset button on relay facia or remote electrical reset by interrupting the control supply.

The red LED can also be used to determine actual load current being drawn from the supply without the need for an ammeter. By turning the current adjustment (2) clockwise from the fully anti-clockwise position, the LED will begin to flash when the actual load current is reached. The current can be determined by reading the calibrated scale and is an advantage where high accuracy is required.

## Fine Underload Adjustment

- Set the trip time adjustment (1) to the required trip time.
- Follow the above procedure to obtain the actual load current.
- Set the current adjustment (2) to just below the actual load current.

Any load current below the preset level will cause the EUCR-2C to trip after the trip time adjustment has elapsed

## Test and Reset

Via two push buttons on the front facia. The test button allows the operator to test the functionality of the relay when control power is applied and motor is running. The reset button allows the relay to be reset instantaneously. Remote electrical reset is also possible by interrupting the control power supplied to terminals L1 and L2.

## Mounting

The EUCR-2C is 35mm DIN rail mounting and is supplied with a bracket for surface mounting if required. It can be mounted in any orientation without affecting performance.

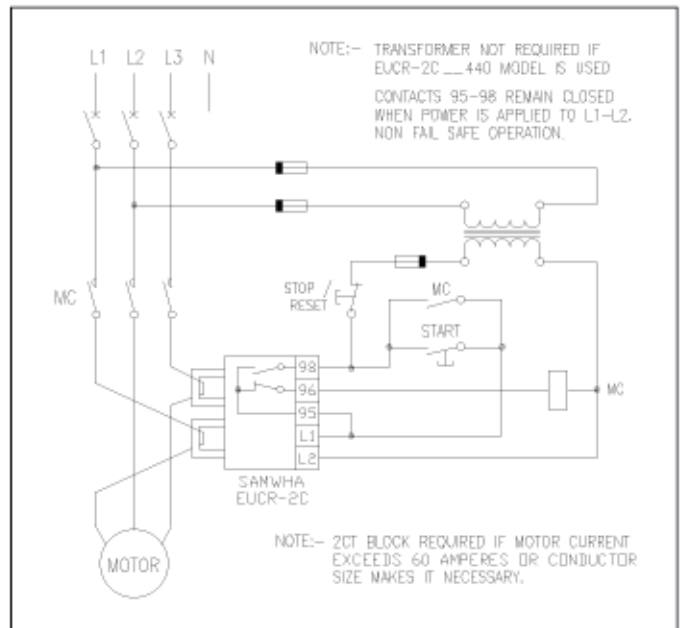

Typical wiring diagram

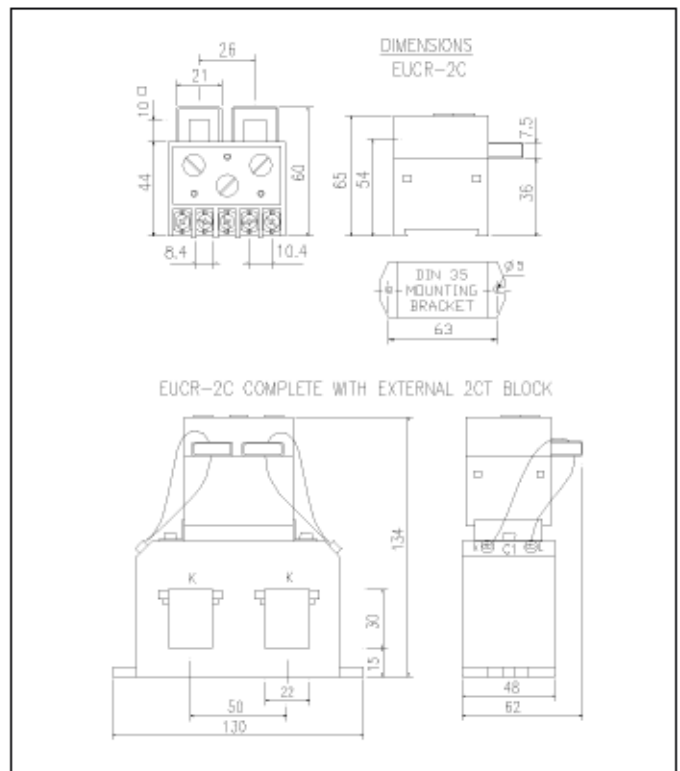

Dimensions

Details may be subject to change without notice.